

Characteristics	1.1 Manufacturer		Clark		
	1.2 Manufacturer's model designation		C PS 15P		
Characteristics	1.3 Drive : E (electric)		E		
	1.4 Type of control : T (tiller) S (steering wheel) A (pedestrian) P (standing) R (seated)		T / P		
	1.5 Load capacity	Q (t)	1.5		
	1.6 Load centre distance	c (mm)	600		
	1.8 Load distance, centre of drive axle to fork	X (mm)	665		
Weights	1.9 Wheelbase		Y (mm)	1.300	
	2.1 Service weight (battery included)		Kg	1.200	
	2.2 Axle loading (with load)	front / rear	Kg	955 / 1245	
Wheels - Chassis	2.3 Axle loading (without load)		front / rear	Kg	840 / 360
	3.1 Tyres : plt (polyurethane) vlk (vulkollan)		vlk		
	3.2 Front wheels size		mm	245	
	3.3 Rear wheels size		mm	85	
	3.4 Stabilizers wheels dimensions		mm	150	
	3.5 Wheels : number front / rear (x = traction)		1x + 1 / 2/4		
	3.6 Front track width		b 10	600	
Dimensions	3.7 Rear track width		b 11	380	
	4.2 Lowered mast height		h1 (mm)	2.105	
	4.3 Free lift		h5 (mm)	1.560	
	4.4 Lifting height		h3 (mm)	3.100	
	4.5 Extended mast height		h4 (mm)	3.700	
	4.6 Free lift				
	4.9 Height of tiller arm in drive position (min / max)		h14 (mm)	1.200 / 1.480	
	4.15 Forks lowered height		h13 (mm)	90	
	4.19 Total length		l1 (mm)	2.038 / 2.468	
	4.20 Length to forks face		l2 (mm)	888 / 1.318	
	4.21 Overall width		b1 / b2 (mm)	880	
	4.22 Forks dimensions		s / e / l	70 / 180 / 1.150	
	4.24 Fork carriage width		b3 (mm)	665	
	4.25 Width over forks		b5 (mm)	560	
	Performances	4.32 Ground clearance		laden	m2 (mm)
4.33 Aisle width for pallets 1000 x 1200 forking side 1200		Ast3 (mm)			
4.34 Aisle width for pallets 800 x 1200 forking side 800		Ast3 (mm)		2.290 / 2.720	
4.35 Turning radius		Wa (mm)		1.700 / 2.130	
5.1 Travel speed		laden / unladen	Km / h	8.5 / 9.5	
5.2 Lifting speed		laden / unladen	m / s	0.12 / 0.18	
5.3 Lowering speed		laden / unladen	m / s	0.45 / 0.4	
5.7 Gradient performance (S2 30 min)		%			
5.8 Max gradient performance (S2 5 min)		%		6 / 10	
5.10 Service brake M (mechanical) I (hydraulic) IV (inversion braking)				IV	
El.Motor	6.1 Traction motor, rating S2 60 min		KW	2	
	6.2 Lifting motor, rating S3 15%		KW	3	
	6.3 Battery according DIN 43531 / 35 / 36 A, B, C, no		no		
	6.4 Battery voltage, nominal capacity K5		V / Ah	24 / 300	
	6.5 Battery weight (± 5 %)		Kg	200	
Others	8.1 Type of travel control		MOS DC		
	8.4 Sound level at driver's ear		dB (A)	< 70	
Technical specification according to VDI 2198				DS.033EN.REV.02	

All values shown are for standard lift truck with standard equipment. If the truck is supplied with options, values may change. All values given may vary +5% and -10% due to the motor and system tolerances and represent nominal values obtained under typical operating conditions.

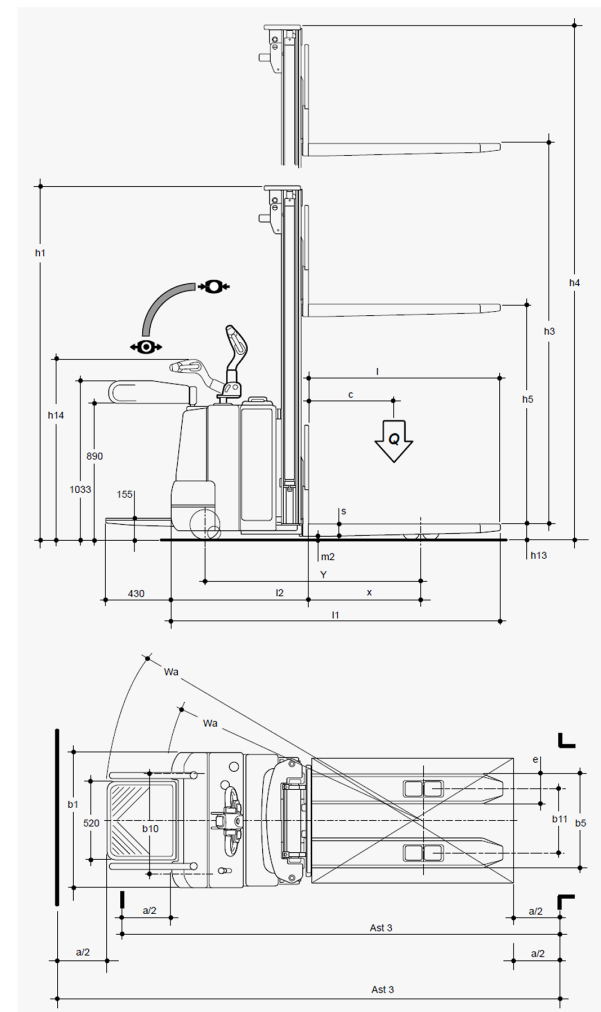

					715 P
h3		h1	h4	h5	(Q) t
1.650	mm	2.085	2.250	1.565	1.5
2.800	mm	1.955	3.400	1.410	1.5
3.100	mm	2.105	3.700	1.560	1.35
3.600	mm	2.355	4.200	1.810	1.15
4.200	mm	1.955	4.800	1.410	0.9
4.650	mm	2.105	5.250	1.560	0.75